

COMPLIANCE

- Approved tank design registered with WorkSafe
- Approved tank fabricator registered with WorkSafe

PAINT

- Sandblasted
- 2K Epoxy primer
- 2K Polyurethane Topcoat
- Colour of your choice

PUMP OPTIONS

- 230V Standard flow electric pump (approx. 50lpm)
- 230V Hi-flow electric pump (approx. 90lpm)
- Honda WB20 petrol pump
- 12V & 24V options available
- Solar powered options available
- Dual pump options available

FUEL MANAGEMENT

- Everlink Advanced Fuel Management System
- Everlink Lite
- Everlink Micro
- Please get in contact for more info

EQUIPMENT INCLUDES

- ZVA auto shut off nozzle with built in breakaway
- Donaldson filtration – 10 Micron
- Piusi K44 meter
- Over fill alarm
- Bund alarm
- Hose boom
- 25mm swaged end fuel hose
- Emergency Stop (electric only)
- Anti-Syphon valve
- Dry Break fill coupling
- Dipstick
- Vent
- Hazchem signage
- Lockable pump cabinet and fill dip hatch
- Auxiliary suction and return ports
- Ladder to access dip point

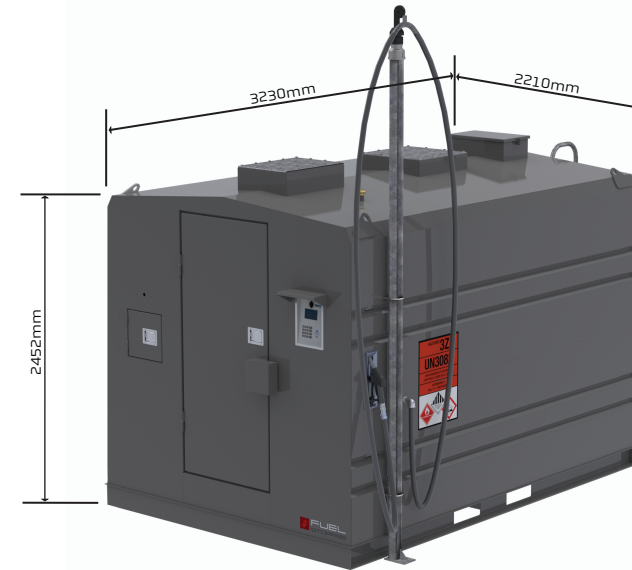

Optional Concrete Pad

